

A 3 T superconducting magnet for long-run magnetic Compton-scattering experiments

Nobuhiko Sakai,^{a*} Hiroshi Ohkubo^b and Yasushi Nakamura^b

^aMaterial Science Division, Himeji Institute of Technology, 1475 Harima Science Garden City, Ako-gun, Hyogo 678-1297, Japan, and ^bCryogenic Division, Suzuki Shokan Co. Ltd, 8-52 Yoshinodai, Kawagoe City, Saitama 350-0833, Japan. E-mail: n_sakai@sci.himeji-tech.ac.jp

(Received 4 August 1997; accepted 5 November 1997)

A 3 T superconducting magnet has been designed and constructed for magnetic Compton-profile (MCP) measurements with the new capabilities that the magnetic field direction can be altered quickly (within 5 s) and liquid-He refill is not required for more than one week. For the latter capability, two refrigerators have been directly attached to the cryostat to maintain the low temperature of the radiation shields and for the recondensation of liquid He. The system has been satisfactorily operated for over one week.

Keywords: superconducting magnets; cryocooler; magnetic X-ray scattering.

1. Introduction

X-ray scattering experiments using circularly polarized X-rays frequently use external magnetic fields to magnetize samples. In these cases high magnetic fields are indispensable for magnetically hard samples, such as those containing Co atoms or 4f elements. Although a superconducting magnet is suitable for this purpose, the time required to alter the field direction is usually comparable to a data accumulation time, a few 10 s, which is required to compensate for unexpected fluctuations of the X-ray beam. In order to avoid the loss of accumulation time due to this magnetic field alternation time, a rapid change of the helicity of the circularly polarized X-rays would be a clear solution, if the degree of linear polarization is exactly maintained. For relatively low-energy X-rays, two set-ups for this are under construction at SPring-8 beamlines: one is a pair of helical undulators and the other is a wave-shift retarder. However, these are not effective for higher-energy X-rays above 100 keV. We thus rely on quick alternation of the direction of the magnetic field on the sample.

2. Design concept

A 3 T superconducting magnet has been designed and constructed for magnetic Compton-profile (MCP) measurements with the new capabilities that the magnetic field direction can be altered quickly by changing the current direction (within 5 s) and liquid-He refill is not required for more than one week, which is long enough to measure an ordinary set of MCP data. The following requirements have also been considered: field unifor-

mity within 2% in a central region 10 mm long × 10 mm diameter, a horizontal room-temperature bore of 51 mm diameter, liquid-nitrogen-free radiation-shield cooling, a total weight less than 250 kg and a power supply controlled by external turn-up and turn-down signals.

2.1. Superconducting magnet

Energy losses caused by a.c.-like operation of the magnet will be divided into (i) hysteresis losses due to the magnetization of the superconducting magnet, (ii) ohmic losses due to eddy currents induced in conductive parts of the magnet, and (iii) ohmic losses due to eddy currents induced in the Cu matrix of the superconducting wire. It is found that the loss denoted by (i) is dominant for the present magnet. The hysteresis loss can be approximated by (Wilson, 1983)

$$Q_h = \frac{8}{3\pi} a J_{CO} B_0 \left[\frac{B_m + B_0}{B_m} \ln \left(\frac{B_m + B_0}{B_0} \right) - 1 \right],$$

where a is the radius (4.5 μm) of the superconducting filament in the twisted wire, J_{CO} is the critical current density ($2 \times 10^{10} \text{ A m}^{-2}$), B_m is a maximum field (3 T) and B_0 is a constant depending on the hard superconducting material (0.34 T). According to the equation, it is more effective to use a wire composed of smaller-radius filaments. The diameter of the adopted superconducting wire is 0.6 mm, and the ratio of volume for superconductor and copper is 1:1.3. The superconducting wire consists of 7500 filaments, with a twist pitch of 20 mm. The hysteresis loss has been estimated under the condition that the magnet is excited or de-excited every 35 s (0.0143 Hz): excitation is from -3 T to $+3 \text{ T}$ or *vice versa* in 5 s and the field 3 T (or -3 T) is then kept constant for 30 s. The calculated value is 0.29 W, which is allowable for the desired rate of liquid-He consumption.

2.2. Cryostat

The liquid-He bath is designed to be guarded from external radiation by double shields. The temperatures of the shields are maintained by a two-stage refrigerator. The temperature of the outer shield (connected to the first stage of the refrigerator) is kept at less than 70 K while withstanding the following heat loads: the radiation power from the outer room-temperature environment (estimated to be about 20 W), heat input through pipes (11 W) and through Cu current leads (4 W) from the room-temperature region, and ohmic loss energy due to the excitation current and the eddy current (2 W). The temperature of the inner shield (connected to the second stage of the refrigerator) is kept at less than 20 K against the radiation from the outer shield and the bulk conductive heat input, which are estimated to be less than 1 W.

It should be noted that radiation-shield tubes for the room-temperature bore penetrating the magnet cause eddy current losses induced by the a.c.-like operation of the magnet. Therefore slits were introduced in the tubes along the field direction to reduce the total cross section of the current loops. A reduction of nearly a factor of ten could be achieved by this treatment.

2.3. Electrical lead

The electrical lead to the magnet consists of three parts: a phosphorus-deoxidized Cu lead, an HTS (high-temperature superconductor) lead and an NbTi lead. The first part, the Cu

lead, is thermally anchored to the outer radiation shield through nitrated aluminium thermal conductors and then electrically connected to the second part, the HTS current lead (American Superconductor Company, USA), which runs to the liquid-He bath. The matrix of the HTS lead is made of an Ag alloy, instead of pure Ag, to reduce the bulk thermal conductance. The estimated ohmic loss is about 4 W per lead for 90 A operation. The heat input through the HTS lead is estimated to be less than 80 mW per lead. The third part of the lead is composed of an NbTi superconducting wire of 0.6 mm diameter together with a Cu wire of 0.8 mm diameter. Flexible joints are used between the HTS and the NbTi/Cu leads.

The overall heat input to the liquid He is about 0.9 W: (i) 0.36 W by bulk conduction, (ii) 0.05 W by radiation, (iii) 0.35 W by hysteresis and eddy currents, and (iv) 0.1 W by the liquid-He level monitor. The consumption of liquid He due to these heat loads can be nearly cancelled by the recondenser, under the gas pressure of the liquid-He bath of less than 0.16 kgf cm^{-2} .

2.4. Interlock system

The power supply to the superconducting magnet is automatically shut off when one of the following two conditions is not satisfied: (i) adequate liquid-He level or (ii) suitable temperature at $P1$ (see Fig. 1). The amount of liquid He is monitored by a level meter composed of a superconducting wire. When the meter indicates a level of less than 170 mm from the bottom, the meter sends an interlock signal. A Pt-Co thermocouple sensor monitors

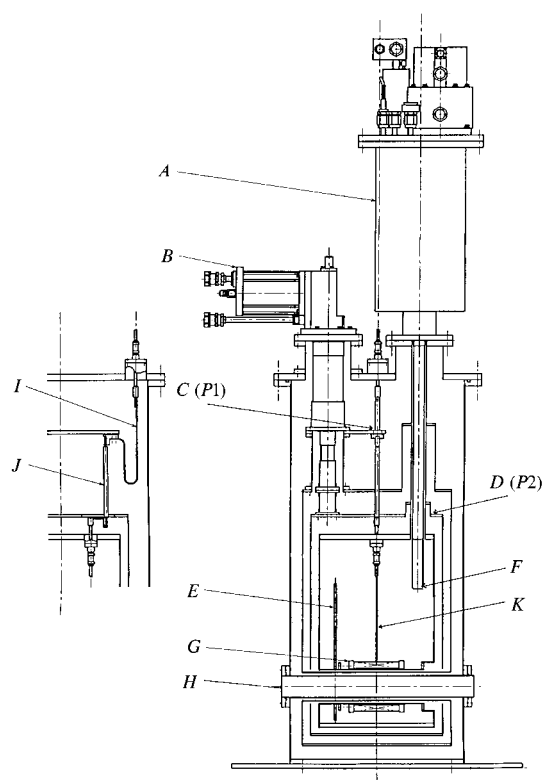

Figure 1 Schematic side view of the cryostat for a superconducting magnet. *A*, He-gas cryocooler; *B*, refrigerator for radiation shields; *C* ($P1$), the first stage shield ($\sim 70 \text{ K}$); *D* ($P2$), the second stage shield ($\sim 20 \text{ K}$); *E*, liquid-He level meter; *F*, 4 K heat exchanger of the cryocooler; *G*, superconducting magnet; *H*, room-temperature bore; *I*, Cu current lead; *J*, HTS current lead; *K*, NbTi superconductor and Cu current lead.

the temperature at $P1$. The shut-off temperature is set at 70 K. The temperature at $P1$ may rise when the refrigerator B is in a bad condition. When the temperature approaches 70 K, the heat loss in the HTS leads increases because of the local break which forms in the superconductive paths, and finally causes severe damage of the HTS leads.

3. Specification

A schematic side view of the assembly of the magnet is shown in Fig. 1. The total height is 1785 mm. The length of the room-temperature bore is 460 mm. The outer jacket and the 27 l liquid-He bath of the container are made of stainless steel (SUS304). A 4 K GM-JT cryocooler for He-gas recondensation (denoted in Fig. 1 by A) has a cooling power of 2.5 W at 4.3 K (CG308SLCR, DAIKIN Industries Ltd, Japan). Another two-stage GM-type refrigerator (denoted by B) has cooling powers of 80 W at 80 K and 12 W at 20 K for the first and the second stages, respectively (RF-70, Suzuki Shokan Company Ltd, Japan). Each stage is connected to a Cu radiation-shield jacket surrounding the liquid-He bath. The size of the magnet coil is 123 mm in outside diameter, 90 mm in inside diameter and 100 mm in length. The inductance is 1.33 H. The magnet is placed 200 mm above the base of the cryostat. The current for 3 T is 78.55 A. The output voltage of the power supply is $\pm 50 \text{ V}$, which is necessary to overcome the counter electromotive force of the coil, excited at a rate of 31.5 A s^{-1} .

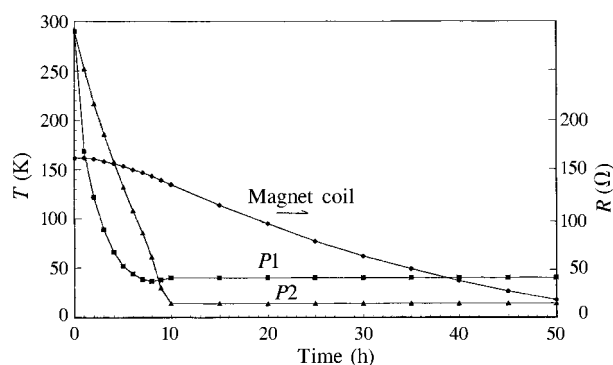

Figure 2 Temperature changes of the radiation shields and the coil after operating the refrigerator B . The coil temperature is monitored by its resistance and 22.5Ω corresponds to 77 K.

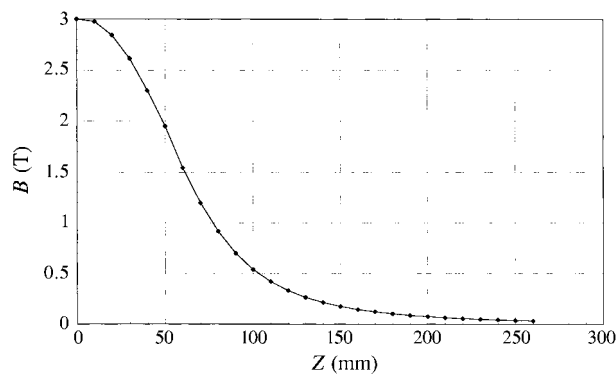

Figure 3 Horizontal magnetic field distribution along the central line.

4. Performance

As shown in Fig. 2, the first (*P1*) and the second (*P2*) stages connected to the refrigerator *B* were cooled to 40 and 15 K, respectively, about 10 h after the start of operation, and the magnet was cooled to around 80 K by He gas after 45 h, without utilizing liquid nitrogen. In this situation, about 23 l of liquid He was charged, and the recondenser *A* was then started.

Without operating the recondenser *A*, the liquid-He consumptions with d.c.- and a.c.-like operations were measured, and were about 540 and 680 ml h⁻¹, respectively. The a.c.-like operation was ramp-type cycles consisting of a cycle of 3 T for 20 s, switching to -3 T in 5 s, -3 T for 20 s, and switching to

3 T in 5 s. The gas pressure in the liquid-He bath was less than 0.2 kgf cm⁻² (1.96×10^4 Pa) during the operation.

A calculated magnetic field distribution along the horizontal direction is shown in Fig. 3. Outside the cryostat, the magnetic field is less than 0.05 T. Samples are placed at the centre of the room-temperature bore. If the sample is to be measured at low temperatures, it can be attached to a cold finger on another refrigerator inserted in the room-temperature bore.

References

- Wilson, M. N. (1983). *Superconducting Magnets*, p. 182, equation (8.65). Oxford: Clarendon Press.