

Short Communications

J. Synchrotron Rad. (1995), **2**, 113–114

Search for new scintillators by studying the fluorescence properties of powdered compounds with synchrotron radiation

Wang Dewu,^a Liu Jianfei,^a Xie Yanning,^a Gu Yifan,^b Chen Yu,^b Sun Hancheng,^c Zhang Jiashan^c and Zhu Zuqi^c

^aBSRF, Institute of High-Energy Physics, Academia Sinica, PO Box 918, Beijing 100039, People's Republic of China,

^bInstitute of High-Energy Physics, Academia Sinica, PO Box 918, Beijing 100039, People's Republic of China, and

^cInstitute of Atomic Energy, PO Box 275, Beijing 102413, People's Republic of China

(Received 20 April 1994; accepted 14 September 1994)

This paper describes a method for investigating the properties of powdered compounds using synchrotron X-radiation. The fluorescence decay times of bismuth germanate, BaF₂, CeF₃ and CsI, as well as the light yields of several samples of gadolinium silicate, prepared in different ways, have been measured.

Keywords: scintillators; fluorescence decay times; light yields.

1. Introduction

It is well known that scintillators of high quality are useful for high-resolution γ -ray calorimeter and imaging devices employed in high-energy physics, nuclear physics and nuclear medicine. For future high-energy physics experiments, new scintillators must be found which possess a faster response, a better resistance to radiation, have a heavy density and which are cheaper (Lecoq *et al.*, 1991).

Different methods have been described to search for new candidates (Derenzo *et al.*, 1990; Herve *et al.*, 1992). Here we describe a new method in which the fluorescence decay times and the light yields of powders can be measured by using X-rays from the Beijing Synchrotron Radiation Facility (BSRF). A major advantage is that with a powder sample, the period of the experiment could be shortened compared with an experiment utilizing a single crystal, in which a longer time would be needed for the preparation of a suitable crystal. The results presented here also agree with those obtained by other methods (Anderson, 1989).

2. Experimental apparatus

The storage ring of BEPC, operating with a single bunch of electrons, has a period of 800 ns and a pulse duration of about 150 ps. X-ray photons of 20.8 keV were selected by a double-crystal monochromator with an energy resolution of $\Delta E/E = 4 \times 10^{-4}$ on beamline 4W1B. The X-ray beam was collimated by a slit to 10×5 mm and used to excite the powder sample in a chamber consisting of six holders. The chamber, with entrance and exit X-ray windows made of kapton film, was evacuated. There is a quartz window close to the sample which is 50 mm in diameter and 5 mm in thickness. Each powdered sample is put in a cylindrical

vial, also made of quartz, which is 15 mm long, 5 mm in diameter and 100 μ m in wall thickness. Photons from the excited powder are able to pass through the vial wall and the quartz window. The fluorescent photons are detected under single photoelectron mode. If more than two photons are counted, the measurement error of fluorescence decay times would increase. The photoelectron signal, having been amplified by a fast amplifier, discriminated by a CFD (constant fraction discriminator) and delayed by a delay line, is used to stop a TAC (time-amplitude converter). The photons which miss the edge of the sample and pass through the kapton window are picked up by a detector composed of a plastic scintillator and a photomultiplier. This gives out a trigger signal to start the TAC, whose output then goes to a multichannel pulse analyzer (MCA) to complete the measurement of the fluorescence decay time. A diagram of the apparatus is shown in Fig. 1.

The fluorescence light yield from the powder is estimated from the photon flux detected by a photomultiplier tube. In addition, an ionization chamber is used for recording the incident X-rays onto the sample so as to normalize the calculation of the light yield, which is necessary for calculating the scintillation intensity.

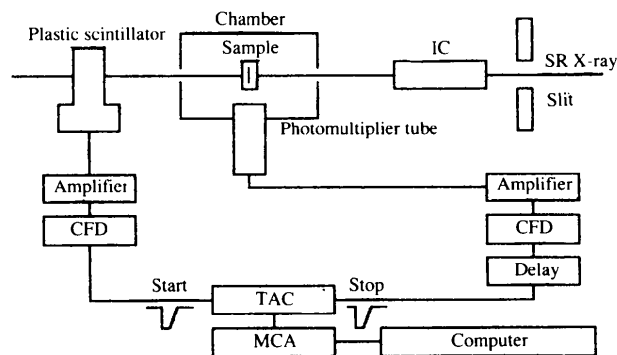

Figure 1

Schematic of the apparatus used to measure the decay times of powdered scintillator compounds with synchrotron X-radiation at the BSRF.

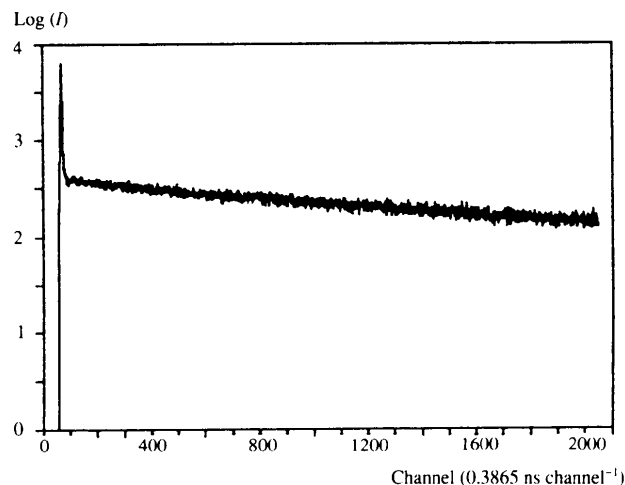

Figure 2

Decay spectrum of barium fluoride.

Table 1

Lifetimes of several powdered scintillators.

Powder	Fast component decay time (ns)	Slow component decay time (ns)
BGO*	30.4 (1.1)†	295.9 (1.8) (300‡)
BGO	29.3 (0.8)†	295.3 (1.3)
BaF ₂	1.90 (0.05)	621.9 (3.6)
CeF ₃	4.3 (0.1)	31.3 (0.7)
CsI	2.50 (0.04)	17.3 (0.2)

* This sample is a single crystal. † Intensity of fast component less than 6%. ‡ Anderson (1989).

Table 2

Relative intensity observed from different GSO powders and the intensity normalized to that of BGO.

Sample	Handling process	Relative intensity I	Relative intensity I_0
BGO	Pure powder	1000	1000
GSO	Deposition	38	69
GSO(1A)	0.5% Ce solution	72	131
GSO(2A)	Drying 1% Ce	94	171
GSO(1B)	1% Ce solution	271	494
GSO(2B)	Drying 1.27% Ce	453	825

3. Results

More than ten powdered samples were observed in the course of these experiments. As an example, the decay spectrum of BaF₂ is shown in Fig. 2 and is quite typical. It can be seen that both a fast and a slow component exist in the same spectrum with characteristic decay times of 1.9 and 621.9 ns, respectively, which are quite close to those estimated by other methods (Anderson, 1989). The data recorded here were fitted by using a function $F(t)$, with the aid of a physics analysis workstation (PAW), whereby the function $F(t)$ is given by:

$$F(t) = \sum_{j=1}^N I \exp(-t/T_j),$$

where $N = 2$. The measured lifetimes of the powders are listed in Table 1.

Our method is sensitive to the scintillation intensity emitted by the powder. The intensity of gadolinium silicate (GSO) from different sources has also been measured. The light yield of GSO was normalized to that of bismuth germanate (BGO). Table 2 shows the results, where the intensity I is the observed fluorescence yield and I_0 is the fluorescence produced at the surface of the powder.

4. Conclusions

The results can be summarized as follows:

(1) The measured fluorescence decay times for the powdered samples BGO, BaF₂, CeF₃ and CsI by this method are in reasonable agreement with previous results (Herve *et al.*, 1992; Anderson, 1989).

(2) By comparing the decay times of a single crystal of BGO and powdered BGO, we suggest that there is no difference between the two types of samples, within error.

(3) It is easy to see from Table 2 that the method described here is sensitive to the sample preparation method and gives a high light yield from the excited powder.

We have demonstrated that the time resolution of the system is better than 1 ns. The very fast component can therefore be measured to this level. Basic research to find novel materials will be continued in the future using this method.

We would like to thank Professor Dong Baozhong for his support of this work and we are grateful to Professor Li Dashi for his help in computing. We also give our thanks to colleagues for light source support at beamline 4W1B. This work was supported by the Natural Sciences Funds of China.

References

- Anderson, D. F. (1989). *IEEE Trans. Nucl. Sci.* **36**, 137–140.
 Derenzo, S. E., Moses, W. W., Cahoon, J. L., Perera, R. C. C. & Litton, J. E. (1990). *IEEE Trans. Nucl. Sci.* **37**, 203–208.
 Herve, A., Lecoq, P., Le Goff, J. M. *et al.* (1992). Report CERN/DRDC/92-02. CERN, Geneva, Switzerland.
 Lecoq, P. *et al.* (1991). Report CERN-PPE/91-23. CERN, Geneva, Switzerland.

J. Synchrotron Rad. (1995). **2**, 114

A source design strategy providing 5 eV–100 keV photons. Erratum

V. P. Suller

Daresbury Laboratory, Warrington, Cheshire WA4 4AD, UK

(Received 8 November 1994)

An error in the paper by Suller [*J. Synchrotron Rad.* (1994). **1**, 5–11] is corrected. The units for the ordinate in the caption for Fig. 7 should be photons s⁻¹ (0.1% bandwidth)⁻¹ mm⁻² mrad⁻² and photons s⁻¹ (0.1% bandwidth)⁻¹, respectively.